

LOGAN COUNTY
TECHNICAL DESIGN
STANDARDS

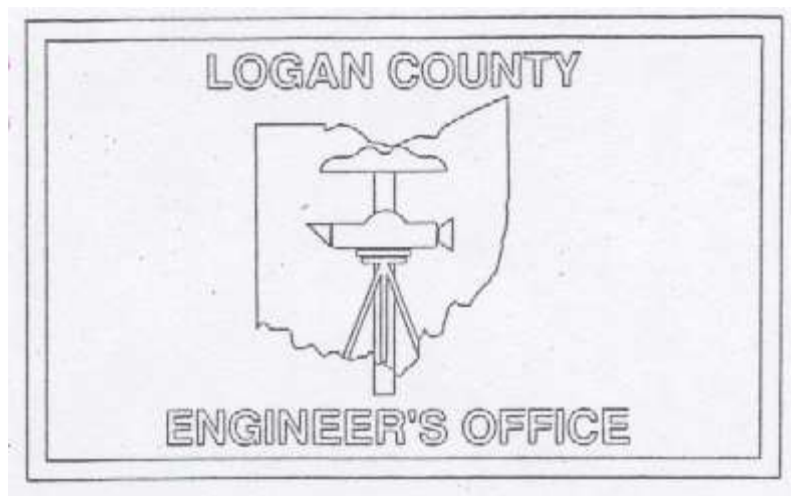

Revised January 15, 2025

Scott C. Coleman, P.E., P.S.

Logan County Engineer

**1991 County Road 13
P.O.Box 427
Bellefontaine, Ohio 43311
(937) 592-2791**

PREFACE

It is the intent of these requirements to provide a standard for subdivisions for the purpose of protecting the public health, safety, comfort, convenience and general welfare; And regulating the development of subdivided areas; Promoting the proper arrangement of streets and layout of lots; Providing for adequate and convenient provision of open spaces, utilities, water, drainage, sewer, and other sanitary facilities.

It is understood that all situations cannot be covered by these requirements and when those situations arise they will be handled as special cases interpreted by the County Engineer's Office.

Articles 1 through 10 of the Subdivision Regulations of Logan County, Ohio are the subject of the hearing required by the Ohio Revised Code. The Technical Design Standards shall serve as an engineering supplement to the Subdivision Regulations of Logan County, Ohio. The County Engineer shall revise the Technical Design Standards from time to time as needed.

TABLE OF CONTENTS

ARTICLE 1 STREET DESIGN STANDARDS	1-1
SECTION 100 PURPOSE	1-1
SECTION 101 STREET DESIGN	1-1
A. Subdivision Street Classifications	1-1
B. Traffic Expansion Factor	1-1
C. Vehicle Demand Factor	1-1
D. Terrain Classification	1-2
E. Development Density	1-2
F. Design Speeds	1-2
G. Vertical Alignment	1-2
H. Horizontal Alignment	1-3
I. Pavement Width	1-4
J. Street Curb and Gutters	1-4
K. County Standard Drawings	1-5
L. Street Access Restriction	1-5
SECTION 102 INTERSECTION DESIGN	1-5
A. Angle of Intersection	1-5
B. Number of Allowable Intersecting Streets	1-5
C. Offset Intersections(Spacing)	1-5
D. Minimum Curb Radius	1-6
SECTION 103 STREET DESIGN STANDARDS FOR CUL-DE-SAC STREETS	1-6
SECTION 104 DRIVEWAYS	1-6
A. Clarifications	1-6
B. Private Driveway Installation	1-7
C. Common Access Driveway (CAD)	1-8
ARTICLE 2 PAVEMENT DESIGN STANDARDS	2-1
SECTION 200 GENERAL INFORMATION	2-1
A. Current Standards	2-1
B. Pavement Type	2-1
C. Soil Supporting Strength	2-1
D. Terminal Serviceability	2-1
E. Traffic and Equivalent Loading	2-1
F. Material Coefficients	2-2
SECTION 201 FLEXIBLE PAVEMENTS	2-3
SECTION 202 RIGID PAVEMENTS	2-4
SECTION 203 SOIL TEST	2-4
SECTION 204 SUBGRADE DRAINAGE	2-4
SECTION 205 SUBGRADE PREPARATION	2-5
ARTICLE 3 DRAINAGE DESIGN STANDARDS	3-1
SECTION 300 PURPOSE	3-1
SECTION 301 ADEQUATE DRAINAGE OUTLET	3-1
SECTION 302 DRAINAGE EASEMENT	3-1
SECTION 304 GENERAL DESIGN CRITERIA	3-2

ARTICLE 4 WATER AND SANITARY SEWER DESIGN CRITERIA	4-1
SECTION 400 CURRENT STANDARDS	4-1
SECTION 401 MATERIALS	4-1
SECTION 402 INSTALLATION	4-1
SECTION 403 WATER LINE DESIGN	4-1
SECTION 404 SANITARY SEWER DESIGN	4-1
SECTION 405 TESTING	4-3
ARTICLE 5 BRIDGE DESIGN STANDARDS	5-1
APPENDIX A INSTALLATION OF WATER AND SANITARY SEWER	A-1
SECTION 1 INSTALLATION	A-1
SECTION 2 TESTING	A-2
A. General	A-2
B. Gravity Sewers	A-2
C. Deflection Test	A-4
D. Force Main Testing	A-5
SECTION 3 STANDARDS OF THE SERVICE PROVIDER	A-5
SECTION 4 MAINLINE SHUT OFF VALVES AND VALVE BOXES	A-5
SECTION 5 CORPORATION STOPS AND CURB BOXES	A-6
SECTION 6 FIRE PROTECTION	A-6
SECTION 7 PRESSURE AND BACTERIA TESTING	A-7
A. Pressure Test	A-7
B. Leakage Test	A-7
C. Chlorination	A-8
D. Bacteriological Testing	A-8
APPENDIX B STANDARD DRAWINGS	B-1
STREET WITHOUT CURB AND GUTTER: DESIGN A TYPICAL SECTION	B-2
STREET WITHOUT CURB AND GUTTER: DESIGN B TYPICAL SECTION	B-3
STREET WITH CURB AND GUTTER	B-4
NON-CURB STREET CUL-DE-SAC	B-5
CURB STREET CUL-DE-SAC	B-6
TEMPORARY TURN AROUND	B-7
CONCRETE COMBINED CURB AND GUTTER (COLLECTOR AND ARTERIAL STREETS)	B-8
CONCRETE COMBINED CURB AND GUTTER (LOCAL STREETS)	B-9
CURB RAMP DETAIL	B-10
STORM SEWER	B-11
AGGREGATE DRAIN DETAIL	B-12
DRIVE INLET DETAIL	B-13
DRIVE SPECIFICATIONS	B-14
PAVEMENT REPAIR SPECIFICATIONS	B-15
BRIDGE TERMINAL ASSEMBLY DETAIL	B-16
BRIDGE ANCHOR ASSEMBLY DETAIL	B-17
APPENDIX C SCHEDULE OF FEES SUBDIVISION PLAT FILING	C-1
SUBDIVISION PLAT ENGINEER REVIEW AND INSPECTION FEE	C-2
STORMWATER AND SEDIMENT CONTROL PERMIT AND INSPECTION FEE	C-3
APPENDIX D ACCESS MANAGEMENT REGULATIONS	
APPENDIX E COMMON ACCESS DRIVE (CAD) REGULATIONS	

ARTICLE 1 STREET DESIGN STANDARDS

SECTION 100 PURPOSE

- A. These design standards shall control the manner in which streets and other elements of subdivision improvements are designed and arranged within the subdivision. These standards shall be considered minimum guidelines to insure the safety and welfare of the public.
- B. The use of standards higher than those which are required herein is recommended. In all cases, every effort should be made to use the best possible standards that are consistent with the terrain and type of development proposed. The County Engineer may waive or reduce these requirements based on sound engineering judgment. However, these standards shall not be waived or reduced without prior approval of the County Engineer.

SECTION 101 STREET DESIGN

A. Subdivision Street Classifications

These classifications are the designations of streets and highways according to the function and volume of traffic, measured as Average Daily Traffic (A.D.T.) on each street.

- 1. **Collector Streets** have the primary purpose of intercepting traffic from intersecting local streets and carrying this traffic to higher category roads. A secondary function is to provide access to abutting land uses.
- 2. **Local Streets** represent the lowest category. Their primary function is to provide access to abutting land use.

B. Traffic Expansion Factor

Except for local and collector streets, the design traffic count on all streets shall be expanded for a twenty (20) year growth period using a minimum factor of 2.5 percent per year for rural areas and a higher percentage per year shall be used within any planning area as determined by the County Engineer.

C. Vehicle Demand Factor

An A.D.T. demand for street design shall be taken to be ten (10) vehicles per dwelling unit per day. Additional vehicles due to other related factors must also be taken into account when determining vehicle demands. A minimum A.D.T. of two hundred (200) vehicles shall be used for the design.

D. Terrain Classification

The definitions of terrain classifications within the county are as follows:

1. **Level:** grade range of 0 to 5 percent
2. **Rolling:** grade range of 5 to 15 percent
3. **Hilly:** grade of over 15 percent

E. Development Density

Density classifications in terms of average net land area per dwelling unit are:

Low: not less than 10,800 square feet per dwelling unit,

Medium: not less than 5,400 square feet per dwelling unit, and

High: less than 2,700 square feet per dwelling unit.

F. Design Speeds

The design speeds are as shown.

Design Speed	
Street Classification	Design Speed
Local Street	25-30 mph
Collector Street	35 mph
All Other Roads	45-55 mph

G. Vertical Alignment

All changes in grade shall be connected by vertical curves, the minimum length shall be as follows:

- a. Twenty (20) times the algebraic difference in the rates of grade for local and collector streets and all others based on the requirements of the County Engineer.
- b. The minimum length of vertical curves shall be one hundred (100) feet.

- c. A minimum stopping sight distance of two hundred (200) feet or as defined by the road classification.

Stopping Sight Distance	
Street Classification	Distance
Local Street	200 feet
Collector Street	250 feet
All Other Roads	550 feet

- d. No street grade shall be less than 0.24 percent and in no case shall the grade on a collector street be more than three (3) percent within one hundred (100) feet of an intersection. Lesser classifications of streets shall in no case have a street grade in excess of 6 percent within one hundred (100) feet of an intersection.

Maximum Street Grades For Local and Collector Streets	
Terrain Classification	Street Grades
Level	6%
Rolling	8%
Hilly	12%

H. Horizontal Alignment

Horizontal Alignment should be designed to as high a standard as is possible based on the topography, terrain, and design traffic. Sudden changes between curves of widely different radii or between long tangents and sharp curves should be avoided. Where it is possible, tangent distance of a least one hundred (100) feet should be introduced between reverse curves. The radius of curvature on the centerline of streets shall not be less than the following:

Minimum Radius of Curvature	
Street Classification	Radius of Curvature
Local Street	150 feet
Collector Street	300 feet
All Others	Based on the ODOT Location and Design Manual

Minimum horizontal visibility, measured on the centerline, shall be:

Minimum Horizontal Visibility	
Street Classification	Horizontal Visibility
Local Street	150 feet
Collector Street	300 feet
All Others	Based on the ODOT Location and Design Manual

I. Pavement Width

The pavement widths for each type of street, and type of use, are as shown. These widths shall be considered as the minimum widths allowed, and may be increased as the County Engineer deems necessary, in order to conform to the traffic and parking requirements of the area. Pavement width on curb and gutter type streets is measured from face to face of gutter.

Minimum Pavement Width		
Type	Local	Collector
Without Curb and Gutter	20 feet	24 feet
With Curb and Gutter	28 feet	36 feet

J. Street Curb and Gutters

The requirement of curbs and gutters will vary according to the character of the area and density of development.

Curbs and gutters shall be required within the following area:

- a. In areas where the predominate lot width is one hundred (100) feet or less.
- b. In areas where curbs exist on abutting properties, their extension shall be required throughout the proposed subdivision.
- c. In commercial developments, or where other similar intensive urban uses exist or are anticipated.

Curb and gutters may be required within the following areas:

- a. In areas of high residential density.

- b. In areas near any city or village as required by municipal regulations.
- c. In areas of notable flash flooding, heavy rain runoff, flat topography, or particular drainage problems.

Curbs and combined curbs and gutters shall be constructed in conformance with the current "Construction and Materials Specifications" of the State of Ohio, Department of Transportation and the County Standard Drawing.

K. County Standard Drawings

Refer to the County Standard Drawings for other design information.

L. Street Access Restriction

When required by the County Engineer and based on safety considerations and the need to maintain traffic capacity, the direct access to lots along collector streets and other roads may be prohibited or managed.

SECTION 102 INTERSECTION DESIGN

Intersections shall be designed in conformance with the **ODOT Location and Design Manual, Volume One, Roadway Design** (latest edition) and the standards listed below, whichever are more restrictive.

A. Angle of Intersection

Streets shall be laid out to intersect as nearly as possible at right angles and no street shall intersect any other street at an angle of less than eighty (80) degrees. Streets shall remain at such an angle of intersection for at least 100 feet beyond the intersection.

B. Number of Allowable Intersecting Streets

Three-way intersections are encouraged and in no event shall an intersection greater than four way be approved.

C. Offset Intersections(Spacing)

Intersection spacing of less than two hundred fifty (250) feet should be avoided whenever possible.

Minimum Centerline Offset of Adjacent Intersection			
Connection Type	Local	Collector	Other Roads
Local to	250 feet	360 feet	1,320 feet
Collector to	-	500 feet	1,320 feet
Other Roads to	-	-	1,320 feet

D. Minimum Curb Radius

The minimum pavement radius at intersections shall be 35 feet; the minimum right of way radius shall be 35 feet. The minimum curb radius shall be as follows:

Minimum Curb Radius			
Connection Type	Local	Collector	Other Roads
Local to	35 feet	35 feet	50 feet
Collector to	35 feet	35 feet	50 feet
Other Roads to	50 feet	50 feet	50 feet

SECTION 103 STREET DESIGN STANDARDS FOR CUL-DE-SAC STREETS

The design and improvements standards contained herein are minimum for cul-de-sac streets in residential subdivisions. All such streets shall be designed and constructed in accordance with standards as specified in the following table. Cul-de-sacs are required whenever a street is intended to be permanently dead-ended.

Street Design Standards for Cul-De-Sac Streets	
Maximum Cul-De-Sac Length	10 times average lot frontage
Minimum Radius of Street Right of Way	70 feet uncurbed
	60 feet curbed
Minimum Radius of Pavement	50 feet

SECTION 104 DRIVEWAYS

A. Clarifications

- a. The Access Management Regulations for Logan County (effective 07-24-2017) are incorporated by reference (see Appendix D).

- b. Driveways shall be located consistent with Logan County Access Management Regulations.
- c. Access roads or vehicular ways within the subdivisions containing single family attached dwelling units or multi-family dwellings shall be considered streets and designed and constructed according to these regulations.
- d. A driveway permit indicating the access point as approved shall be obtained from the office of the county engineer or the Ohio Department of Transportation.
- e. Corner lots shall have their drives located on the lower classification roads and as approved by the County Engineer.
- f. For any driveway with a gate, the gate shall be located such that the gate is at least 100 feet from the nearest pavement edge of the public road. No gate shall be located within the public right of way.
- g. Driveway design is dependent upon the type of vehicles that will regularly use the driveway as well as the volume of traffic. Restrictions on turn movements may also effect the design.

B. Private Driveway Installation

The purpose is to develop a consistent regulation for the construction of private entrances on public road rights of way. The following regulations apply:

- a. All private drives that are to be constructed shall be the responsibility of the individual requesting the driveway.
- b. A permit must be obtained from the County Engineer or the appropriate authority. No construction shall start unless a permit is obtained.
- c. The County Engineer, or the appropriate authority shall determine the size (diameter) of the culvert pipe required.
- d. No culvert shall be less than 30 feet in length. Longer lengths may be required if the engineer finds it necessary. Headwalls may only be installed with the prior approval of the County Engineer, or the appropriate authority.
- e. No driveway shall intersect a public road at an angle of less than 70 degrees. 90 degrees is desirable.

- f. All culverts shall be corrugated metal pipe (C.M.P.), reinforced concrete, double walled polyethylene drainage pipe equivalent to Hancor Hi-Q or ADS N-12, or an approved type of equal strength. All fittings shall be manufactured for the type of pipe being installed.
- g. Backfill for the culvert shall be stone or gravel aggregate of size No. 304, 310 or equivalent.
- h. The grade shall be on the flow line of the existing ditch and shall slope with the natural grade of the side ditch unless otherwise directed by the County Engineer, or the appropriate authority.
- i. From the viewpoint of safety, it is suggested that the driveway be located so as to have a minimum of 550 feet sight distance each way on the public road and a driveway grade should be no greater than 10%.
- j. See standard drawings for driveway detail.
- k. The owner shall be responsible for the purchase of all materials and the installation of the materials and shall pay all the costs of said materials and labor.
- l. The County Engineer, or the appropriate authority shall inspect the driveway after construction to check compliance of the above.
- m. The driveway and drive pipe shall be replaced if not installed properly or not kept in good working condition. If replacement is not completed within 15 days after notification by the County Engineer's Office, the county will do the work and the cost will be assessed to the property owner.

C. Common Access Driveways (CAD)

CAD's are encouraged for all applicable lots. CAD's shall be installed in accordance with the above requirements and also in accordance with the regulations contained in Appendix E.

ARTICLE 2 PAVEMENT DESIGN STANDARDS

SECTION 200 GENERAL INFORMATION

A. Current Standards

The current list of standards to be used in the design of new subdivision streets or street improvements are as following:

1. ODOT Construction and Materials Specifications by State of Ohio Departments of Transportation (latest edition).
2. Construction Standards of Logan, Union, and Champaign Counties.
3. ODOT Location and Design Manual, Volume One, Roadway Design (latest edition).
4. ODOT Pavement Design & Rehabilitation Manual
5. Or any alternative approved by the County Engineer.

B. Pavement Type

1. A developer, through his engineer, shall select the type of pavement to be constructed in his subdivision as follows:
 - a. Portland Cement Concrete
 - b. Asphalt Concrete
 - c. Composite

C. Soil Supporting Strength

The supporting strength of the subgrade shall be determined by a recognized soil-testing laboratory acceptable to the County Engineer, or the poorest condition (California Bearing Ratio (CBR)=2.5) for the county may be assumed. Soil stabilization may be considered to improve supporting strength.

D. Terminal Serviceability

An economic analysis regarding the pavement type shall be performed. Major resurfacing will be assumed when the Present Serviceability Index (PSI) drops to 2.00 for Local Streets, 2.25 for Collector Streets, and 2.50 for other roads. A design life of twenty (20) years shall be used.

E. Traffic and Equivalent Loading

Pavement design shall be based on an equivalent daily 18,000 lb single axle application. Actual or estimated traffic counts shall be required for each street. The County Engineer will determine the classification for all streets in the subdivision.

1. **Local Street:**
Shall have a 20 year design subjected to at least four axles per lane per day at the legal load limit.
2. **Collector Street:**
Shall have a 20 year design subjected to at least 30 axles per lane per day at the legal load limit.
3. **Other Roads:**
Shall have a 20 year design subjected to at least 100 axles per lane per day at the legal load limit.

A minimum Load Safety Factor (LSF) of 1.5 for local and collector streets (2.0 for other roads) shall be used.

Design calculations shall be based on the ODOT design methods and shall be submitted with a copy of the soil tests for approval by the County Engineer.

F. Material Coefficients

The following coefficients for various types of materials shall be used with the ODOT design equations:

Material Item	Material	Coefficient
Item 305	Portland Cement Concrete	0.5
Item 301, 302, 403, 404	Asphalt Concrete	0.35
Item 304	Aggregate Base	0.14
Item 310	Subbase	0.11

SECTION 201 FLEXIBLE PAVEMENTS

Absolute Minimum Allowable Pavement Cross-Section Designs*		
Street classification	Flexible Pavement Cross-Section	Notes
Residential Local** SN	1.25" of 448 - Type 1 1.75" of 448 - Type 2 4" of 301 or 302 6" of 304 3.29	**Variance may be granted from "Residential Local" Cross-section if ADT < 200 AND at discretion of County Engineer
Residential Collector SN	1.25" of 448 - Type 1 2.75" of 448 - Type 2 6" of 301 or 302 6" of 304 4.34	
Other Collector & Arterial	To Be Determined	Design Pavement Based on Traffic Volumes & Development
<p>* Pavement design calculations still required in accordance with Section 200, A-F</p> <p>Item 448 - Type 1 Asphalt Concrete (surface course) Item 448 - Type 2 Asphalt Concrete (intermediate course) Item 301, 302 Bituminous Aggregate Base Item 304 Aggregate Base SN Structural Number</p>		

A prime coat (Item 408) shall be required between Item 304 and Item 301 or 448. The application rate shall be at least 0.50 gal per sq. yd. A tack coat (Item 407) shall be required between Item 301 and Item 448. The application rate shall be at least 0.10 gal, per sq. yd.

Minimum asphalt concrete for any flexible pavement with aggregate base shall be 3" on Local street, and 4" on Collector streets and other roads. Item 448 Type 1 Asphalt Concrete shall be used as a surface course and shall not be less than 1 1/4" in thickness. A minimum of 6" aggregate base is required for drainage.

SECTION 202 RIGID PAVEMENTS

The Modulus of Rupture shall be considered to be 600 psi. The absolute minimum allowable design under the worst conditions (K=100) shall be:

Local Street	Collector Street	Arterial Street
6 inches	6 inches	9 inches

In no case shall the minimum thickness of the pavement be less than five (5) inches. A minimum of 6" aggregate base shall be required for drainage.

SECTION 203 SOIL TEST

If the developer desires to seek soil tests, rather than assuming a CBR value of 2.5, the engineer shall first discuss the same with the County Engineer. One test shall be furnished for every 1,000 linear feet of street with a minimum of two tests per street or more as determined by the County Engineer. These tests shall be made at the design subgrade elevation and to a minimum depth of three (3) feet. The worst CBR shall be used for the design.

The tests shall include the following:

1. Soil samples at subgrade elevation and depth of boring.
2. Moisture determination and maximum dry weight of soil.
3. AASHTO classification and group index (each sample)
 - a. Liquid Limit
 - b. Plastic Limit
 - c. Plasticity Index
4. Mechanical Analysis of the subgrade soil.
5. Laboratory C.B.R. tests compacted to the subgrade density as specified in the subgrade preparation section.

SECTION 204 SUBGRADE DRAINAGE

Where unusually wet soil conditions exist as determined by the County Engineer, or where curbs are proposed, 4" to 6" pipe underdrains shall be required. The drains shall be placed in accordance with Item 605 Underdrains. The drains shall be located 2 feet behind the curb, or at the outside edge of the berm and placed a minimum of 18" to a maximum of 30" below the subgrade. The underdrains

shall be placed on a slope of 0.24 feet per 100 feet. Aggregate drains shall be placed at 50 – foot intervals on each side of the pavement and staggered so that each drain is 25 feet from the adjacent drain on the opposite side. For super elevated pavements, spacing shall be at 25 feet and drains shall be located on the low side only.

SECTION 205 SUBGRADE PREPARATION

- A. All subgrade shall be prepared and compacted according to Item 203 of the Construction and Materials Specification. Compaction tests, if required, will be performed by the County Engineer, at the expense of the subdivider.

- B. The subgrade and base material to be used shall be approved by the County Engineer prior to the application of any base material. Each material course shall be inspected and accepted before the next succeeding course is placed.

ARTICLE 3 DRAINAGE DESIGN STANDARDS

SECTION 300 PURPOSE

These standards shall serve as the minimum design requirements for the handling of surface water and other drainage. Drainage includes but is not limited to foundation discharge, water softener discharge and geothermal system discharges. These procedures and standards shall govern the development of all new and/or modified drainage systems. The development of such drainage systems shall include the conveyance of surface water to an adequate outlet. The Professional Engineer's highest design priority shall be to eliminate the possibility of major loss of property or loss of life.

SECTION 301 ADEQUATE DRAINAGE OUTLET

Surface water runoff from a development shall be drained off site to an adequate outlet, in accordance with this article and the Logan County Stormwater and Sediment Control Regulations. The location of the outlet shall be approved by the County Engineer. The outlet may consist of a ditch, stream, storm sewer, or approved detention basin having sufficient capacity to accommodate the surface water runoff in a reasonable manner. The outlet downstream of the subdivision shall be improved by the developer as required to properly convey the water runoff from the subdivision and across the adjacent property so that damages from runoff are minimized. The developer shall acquire all easements necessary to perform such work.

SECTION 302 DRAINAGE EASEMENT

- A. An adequate easement shall be required along any tile, detention basin, drainage way, ditch, watercourse, stream, or storm sewer which is not already within the street right-of-way. The easement shall be of sufficient width to allow cleaning, widening, deepening, replacing or otherwise general maintaining of such drainage course.
- B. When required to convey surface water beyond the limits of a proposed subdivision in order to discharge to an approved outlet, the Subdivider shall obtain all easements and/or rights-of-way necessary for construction and/or maintenance.
- C. All drainage easements shall be shown on the final plat and the "final engineering and construction plan." The drainage easements shall be recorded for public use and the maintenance of such drainage courses shall be the responsibility of the property owners receiving direct benefit therefrom, unless otherwise provided. The width of drainage easements shall be 20' minimum or the width of the surface water spread, whichever is greater.

SECTION 304 GENERAL DESIGN CRITERIA

- A. Acceptable methods for calculating storm water runoff volumes, peak rates and storage requirements are tabulated below. A drainage area map shall be submitted showing all areas within the watershed tributary to the proposed development.

STORM WATER QUANTITY					
DRAINAGE AREA (acres)	PEAK DISCHARGE ONLY*	PEAK RUNOFF AND TOTAL RUNOFF VOLUME		STORAGE VOLUME	
		HOMOGEN.	NON-HOMOGEN.	HOMOGEN.	NON-HOMOGEN.
Less than 200	Rational or Peak Discharge	Peak Discharge	Tabular Hydrograph	Graphical	Storage-Indication
200 to 640	Peak Discharge				
Greater than 640	Tabular Hydrograph			Storage-Indication	

Method References:

Rational: (Q=CIA), M.O.R.P.C., Storm Water Design Manual, 1977.

Graphical: M.O.R.P.C., Storm Water Design Manual, 1977, Pg. 143; US Department of Agriculture, Soil Conservation Service, Urban Hydrology For Small Watersheds, Technical Release No. 55, 1986, Chapter 6.

Storage-Indication: M.O.R.P.C., Storm Water Design Manual, 1977, Pg. 143.

Peak Discharge: U.S. Department of Agriculture, Soil Conservation Service, Urban Hydrology for Small Watersheds, Technical Release No. 55, 1986.

Tabular Hydrograph: U.S. Department of Agriculture, Soil Conservation Service, Urban Hydrology for Small Watersheds, Technical Release No. 55, 1986, Chapter 5.

- * USGS Report 89-4126 (Techniques For Estimating Flood-Peak Discharges of Rural, Unregulated Streams in Ohio) may be used for estimated peak flows where storage is not required. This method is applicable for areas in excess of 6 acres.

- B. Critical Storms shall be calculated using the criteria established in the Mid-Ohio Regional Planning Commission Storm Water Design Manual, 1977. Storage facilities and control structures shall be designed such that the post development runoff rate is equal to a one-year predevelopment runoff rate up to the critical storm. The rate of runoff for all storms greater than or equal to the critical storm shall be controlled to limit the peak rate of runoff to the predevelopment peak rate from the same frequency storm.

The permissible peak rate shall be determined as follows:

1. Determine the total volume of runoff from a 1-year frequency 24-hour storm, occurring over the area before and after development.
2. Determine the percent of increase in volume due to development and using this percentage, pick the critical storm from the following table:

If the Percentage of increase in volume of runoff is		The critical storm for discharge limitation will be
equal to or greater than	and less than	
-	10	1 year
10	20	2 years
20	50	5 years
50	100	10 years
100	250	25 years
250	500	50 years
500	-	100 years

Recurrence Interval Years	24-Hour Rainfall Total Inches
1	2.35
2	2.55
5	3.30
10	3.80
25	4.30
50	4.75
100	5.00

- C. Minimum time of concentration shall be 15 minutes in open ditches and 10 minutes for pavement areas. Storm sewers shall be designed for a minimum of a five-year storm (flowing full) and a 10 year storm (to the top of catch basin). Culverts shall be designed for a 25 year storm with the allowable headwater one foot below the edge of pavement elevation and for a 100-year storm with the allowable headwater 2 feet below any existing or proposed first floor levels. A minimum velocity of 3 fps shall be used for designing storm sewers. A maximum velocity of 12 fps shall be used unless special materials are included for protection against scouring. Maximum velocities for discharge into erodible channels depends on the type of soil at the discharge point. See table below:

Channel Material	Maximum Velocity (fps)
Sand or sandy loam	2.5 fps
Firm loam or silts	3.5 fps
Clay, fine gravel	5.0 fps
Shale, hard pan, coarse gravel	6.0 fps

Vegetal-lined Channels (slopes to 5%)	Maximum Velocity (fps)
Alfalfa, crabgrass	3.5 fps
Grass mixture	5.0 fps
Kentucky bluegrass	6.0 fps

- D. Curb inlets shall be spaced to keep the spread of water on the pavement limited to 8 feet measured from the curb for a two year frequency storm. Curb inlets shall also be installed at sag locations to prevent 25 year storm flows from overtopping the street R/W lines. At all intersections, inlets shall be located at the beginning of the upstream curb return before the crosswalk to prevent cross street flow.

The maximum spacing for catch basins shall be 350 feet on curb and gutter streets and 500 feet on streets with roadside ditches.

- E. All control structures shall be designed with an emergency spillway or other outlet to allow for the flow of storm water should the primary means of flow be obstructed. All designs shall account for future maintenance considerations.

- F. Open ditches shall be designed with a side slope no steeper than 3:1, a two foot minimum bottom and a .4% minimum slope.
- G. A routing path for the 100 year storm event shall be planned through the subdivision with drainage easements in place for surface runoff not contained in the storm sewer system.
- H. A grading plan showing first floor elevations and all off-site grading needed for future development of lots shall be required when net lot density equals or exceeds 3 lots per acre.

ARTICLE 4 WATER AND SANITARY SEWER DESIGN CRITERIA

SECTION 400 CURRENT STANDARDS

The current standards to be used for the design of water and sanitary sewer systems for new subdivisions are as follows:

- A. ODOT Construction and Materials Specifications (and Supplemental Specifications) by State of Ohio Department of Transportation (latest edition).
- B. Construction specifications of Logan, Union, or Champaign Counties.
- C. Ohio Environmental Protection Agency, latest guidelines.
- D. American Water Works Association Standards.
- E. Standard Construction Drawings.

SECTION 401 MATERIALS

- A. Materials to be used must be approved by the County Engineer or the local water or sanitary sewer service provider.
- B. Approved materials shall meet all applicable ASTM, ANSI, AWWA and ODOT standards.

SECTION 402 INSTALLATION

See Appendix A

SECTION 403 WATER LINE DESIGN

See Appendix A

SECTION 404 SANITARY SEWER DESIGN

- A. All sanitary sewers shall be designed in accordance with the latest guidelines for sewer design and installation as required by the Ohio Environmental Protection Agency and as specified herein.

The minimum size of gravity sanitary sewers shall be eight (8) inches. Six (6) inch sewer pipe shall be used for house lateral connections. The house

connections shall be of premium joint construction and shall be of the same material as the collector sewer.

B. Design Factors

Gravity sanitary sewers shall be designed using the area "tributary" to the sewer at each sewer section. Design criteria shall be based on the following information:

- a. Projected number of people per acre;
- b. Average sanitary flow of 100 gallons per person per day;
- c. A peaking factor versus average flow curve; (see page 4-4)
- d. Infiltration per 100 acres based on density.

The average daily flow per acre shall be obtained by multiplying the average sanitary flow (100 gallons per person per day) by the number of persons per acre. Design flow shall be developed by multiplying the average daily flow by a peaking factor and then adding the infiltration per 100 acres. Infiltration flow based on population density shall be as follows:

DENSITY (People/Acre)	INFILTRATION (cfs/100 Acre)
2	0.05
4	0.05
12	0.10

Density figured by using minimum lot size to figure lots/acre and multiplied by 2.5 people/dwelling.

The sewer shall be sized and graded to provide for the design flow. A Manning coefficient of $N = 0.013$ shall be used for design purposes.

The sewers shall be sized on the maximum allowable zoning in any adjacent area but not less than four (4) persons per gross acre.

C. Data Submission

The data and calculations upon which the sewer line is based shall be submitted to the ENGINEER at the time of the preliminary plat. The information shall be type written on 8 1/2" x 11" paper and shall include the following:

- a. Average domestic flow in each sewer.
- b. I/I flow in each sewer.
- c. Peak flow in each sewer.
- d. The capacity of each sewer.

D. Design Criteria

All sewers shall be designed in accordance with EPA requirements except as amended herein.

- a. All sewers shall terminate with Manholes.
- b. All sewer lines shall be extended to the property lines as determined by the ENGINEER.
- c. A single ditch is required for each lateral sewer.

SECTION 405 TESTING

See Appendix A

Peaking Factor vs Average Flow Curve

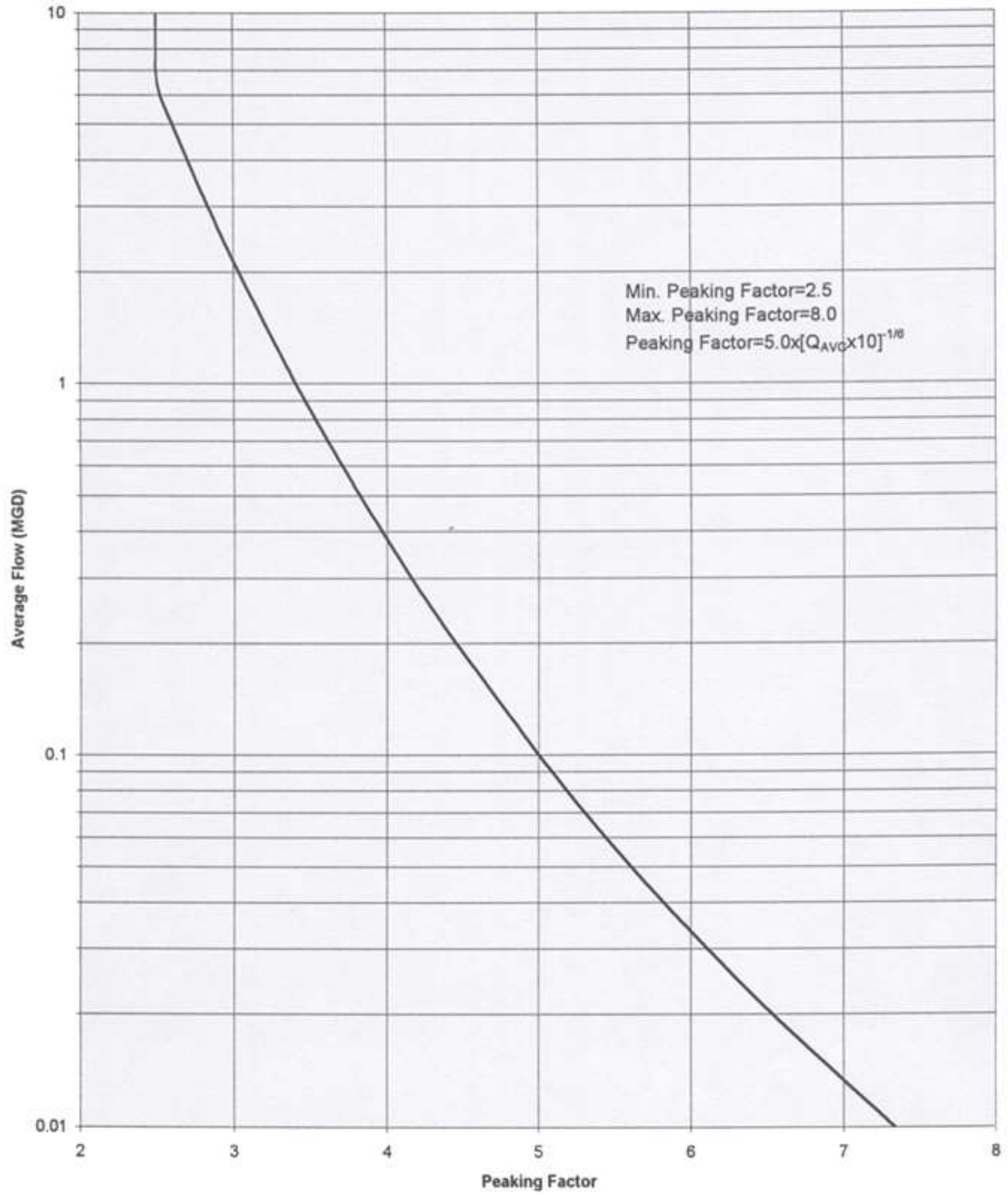

LOGAN COUNTY TECHNICAL DESIGN STANDARDS

ARTICLE 5 BRIDGE DESIGN STANDARDS

SECTION 100 GENERAL

- A.** New construction over \$250,000 and all Federal Aid projects shall incorporate galvanized reinforcing steel, hot dipped or metallized galvanizing of all structural steel components, Ipanex or equivalent alkaline silicate admixture in all concrete to reduce permeability, increase durability, and resist corrosion of reinforcing steel. All welding activities shall be complete prior to galvanizing or hot metallizing.
- B.** Logan County Standard bridge terminal assembly shall be constructed as shown in Figure BDS-1. ODOT standard bridge terminal assemblies may be used as approved by the Logan County Engineer.
- C.** Logan County Standard bridge anchor assembly shall be constructed as shown in Figure BDS-2. ODOT standard bridge anchor assemblies may be used as approved by the Logan County Engineer.
- D.** ODOT Bridge Design Manual.

APPENDIX A

INSTALLATION OF WATER AND SANITARY SEWER

SECTION 1 INSTALLATION

- A. Trench width at the pipe barrel shall not exceed thirty (30) inches or the outside diameter of the pipe barrel plus sixteen (16) inches, whichever is greater.
- B. All pipes shall have a minimum four (4) feet of cover, as measured from the crown of the pipe to the final surface grade.
- C. The trench shall be excavated to a point not less than four (4) inches or 1/4 (one-fourth) the nominal pipe diameter, whichever is greater, below the bottom of the pipe. All loose material shall be removed from the bottom of the trench and a bed prepared using aggregate material as shown on the standard construction drawings. This same granular fill shall be used on the sides of the pipe and a minimum of twelve (12) inches above the pipe.
- D. Backfilling shall begin twelve (12) inches above the top of the pipe with excavated materials. Machine backfilling may be utilized if moved along the trench and not dumped directly on previously placed material. Water or sanitary lines shall be backfilled (full depth) with #8 or #67 stone or Controlled Density Fill when the transverse or longitudinal lengths are at a horizontal distance equal to the vertical depth of the sewer away from the pavement edge.
- E. Unless permission for open cutting is granted by the County Engineer (County Roads) or the Township Trustees (Township Roads), all road crossings shall be bored and placed inside a steel casing with sand blown between the pipe and the casing. Backfilling at the bore pits shall consist of Controlled Density Fill Materials within five (5) feet of the pavement or back of curb, whichever is greater.
- F. All pressure pipe and force mains shall have concrete thrust blocks placed at all bends, tees and hydrants. All bends shall have megalugs or wedge action restraining glands installed as well as blocking.
- G. When required by the County Engineer, all stream crossings shall be placed inside a steel casing with sand blown between the pipe and the casing. Casing and pipe shall be encased with a minimum one (1) foot of concrete for the length of the casing.

SECTION 2 TESTING

A. General

All sewers must be tested under the supervision of the Engineer prior to acceptance.

Testing must be conducted at least 30 days after the full backfill is placed, although an unofficial test prior to that time may be conducted. The subdivider shall pay for all testing.

If the tests are not passed, the Contractor shall be required to locate and remedy the defects in construction causing the infiltration and/or deflection. This test shall be performed again after repair of any section failing the initial infiltration and/or deflection test. Sections, or the system will not be conditionally accepted, until a satisfactory infiltration and/or deflection result is obtained.

All visible leakage in sewers or manholes shall be repaired, even though tests may have been satisfactory.

B. Gravity Sewers

All gravity sewers will be tested by the low pressure air infiltration leakage methods.

In all subsequent references to test pressure, a pressure adjustment shall be made where ground water is above the sewer line being tested, by adding 0.433 psi pressure for each foot the ground water level is above the invert of the pipe, based upon the maximum for the test section. The Contractor shall make provisions for determining the ground water level and the level shall be confirmed by the Engineer.

Test procedures shall be as follows: The sections of pipe to be tested shall be plugged at each end. The ends of all branches, wyes, and laterals shall be sealed or plugged. All plugs shall be braced to prevent slippage or blowout. One of the plugs provided shall have an inlet tap or other provision for connecting an air hose.

Connect one end of the air hose to the inlet tap on the plug and the other end to portable air control equipment, which shall consist of pressure gages and valves to control the rate at which air flows into the test section and to monitor the air pressure within the test section. Pressure gages shall have minimum graduation of 0.1 psi and an accuracy of ± 0.04 psi. The air control equipment shall be connected to a source of air supply such as an air compressor.

Air shall be applied slowly to the test section until the pressure reaches 4 psig (pounds per square inch, gage) plus adjustment for ground water. The pressure inside the pipe shall not exceed 5 psig, plus adjustment for ground water. When the pressure inside the test section reaches 4.0 psig, the air pressure shall be throttled so that the internal pressure is maintained between 4.0 and 3.5 psig for at least two (2) minutes to permit temperature stabilization.

Upon expiration of the two(2) minute period, the air supply shall be shut off or disconnected and the pressure allowed to drop to exactly 3.5 psig. At the exact time 3.5 psig is reached, a stopwatch shall be started and the time required for the pressure to drop to exactly 2.5 psig shall be determined.

Make proper adjustments for ground water, where applicable, in determining the beginning and end of the period for the 1.0 psig pressure drop. The permissible time allocation for the 1.0 psig pressure drop shall be calculated on the basis of the diameter and length of main sewer tested and no adjustment shall be made for service connections included in the test.

The air test for the test section shall be considered acceptable if the time elapsed for the 1.0 psig pressure drop, as previously specified, is equal to or greater than the time, in minutes, indicated on the following table:

LENGTH OF MAIN LINE TESTED						
(IN MINUTES)						
Diameter	100'	200'	300'	400'	500'	600'
3"	2	2	2	-	-	-
6"	2	2	2-2/3	4-1/3	5	-
8"	4	4	4	5-1/4	6-1/2	7-3/4
10"	5	5	5	6-5/6	8-2/3	10-1/2
12"	5-3/4	5-3/4	8-3/4	11-1/2	14-1/2	17-1/4

Time for intermediate lengths shall be interpolated.

The air test shall be unacceptable if the time elapsed is less than the stated period; defects shall be corrected and the line retested. Unless the air test fails due to a leaking plug, a TV inspection of the test section shall be conducted to determine the cause of the failure. This shall be conducted

to determine the cause of the failure, and shall be at the expense of the Developer.

If an infiltration leakage test is used rather than an air test, the maximum rate of infiltration is 100 gallons per inch diameter per mile of pipe, per twenty-four (24) hours. This test is to be conducted when the height of ground water is four (4) feet or more above the elevation of the crown of the pipe at the upstream end of the section of pipe to be tested. If the ground water does not provide sufficient head, the Contractor shall flood the trench to obtain the specified external head.

The measuring device shall be V-notch weir or other measuring device approved by the Engineer.

All tests for acceptance shall be conducted with the Engineer present. Safety precautions shall be carefully observed by the Contractor during air testing, recognizing the danger from plugs blowing out and from loading the sewer line with the full pressure of the compressor. No one shall be allowed in manholes during testing,

C. Deflection Test

If PVC or ABS pipe is used, deflection tests will be run not less than thirty (30) days after final full backfill has been placed. The test is required on all PVC and ABS pipe, regardless of depth, and on all pipes deeper than twelve (12) feet.

Where possible, electronic equipment shall be used to measure and record the deflection in flexible pipe. No pipe shall exceed a deflection of five percent.

If such equipment is not available, the deflection test can be run by use of mandrels, having a diameter equal to 95% of the inside diameter of the pipe, pulled through the sewer line without mechanical pulling devices. Mandrels shall be constructed with at least nine (9) evenly spaced arms or prongs. A metal proving ring shall be provided to verify the accuracy of the mandrel to the Engineer. The length of the mandrel shall be 8" for 8" pipe, and 10" for 10" and 12" pipe.

If any section of conduit exceeds a deflection of five percent, it shall be the Contractor's responsibility to make the necessary corrections to the satisfaction of the Engineer. The costs of all materials, equipment, labor and all incidentals necessary for making the deflection test and for making any necessary corrections or replacement shall be included in the price of the pipe. The deflection test is required to conditional and final acceptance. At the discretion of the Engineer, it may be required that the PVC and ABS sewers be tested for deflection before expiration of the one

year maintenance bond. Conduit, which has deflected more than five percent, must be corrected to the satisfaction of the Engineer by the Contractor.

D. Force Main Testing

A leakage test shall be applied to all force mains. The force main shall remain isolated from adjacent force mains and a pressure of at least 100 pounds per square inch shall be applied by pumping clean water from a clean container through 1-inch corporation stops installed in the ends of the force main, with the Contractor to provide an initial pressure of 110-120 psi.

The pressure test shall be in an afternoon and the pressure shall be on for eighteen (18) hours and then the pressure shall be maintained at 100 psi or more for an additional six (6) hours by pumping water from the container. A minimum test pressure of 100 psi shall be assured by pumping until a pressure 110-120 psi is attained. At the end of the six (6) hour period, the water used shall be measured and the loss by leakage shall not exceed 75 gallons per inch diameter per mile of pipe per 24 hours.

If the force main does not pass the leakage test, the leaks shall be located and repaired, and the testing procedure repeated.

The Developer shall pay the cost of furnishing all material, labor, equipment, and the total volume of water for testing.

SECTION 3 STANDARDS OF THE SERVICE PROVIDER

A Hardy Cross analysis shall be made to verify pipe sizes and the adequacy of projected fire flows and mainline pressures. Where the calculated pipe diameter is smaller than the minimum required (8") the 8" shall be used. The local fire department shall verify that sufficient fire flows are available. A minimum static water pressure of 35 psi must be available at every tapping point along the main. A 20 psi residual pressure is desirable.

SECTION 4 MAINLINE SHUT OFF VALVES AND VALVE BOXES

Shut off valves shall be located on the main at all future stub locations and when the main branches off to serve other areas not fronting the main water line. All shut off valve locations shall be approved by the water service provider. Dead end stubs shall have MJ (mechanical joint) plugs or Clow F1159 solid plugs (super bell tile push on restrained plugs only) on 4" - 12" pipe. On 16" and larger pipes megalug both sides of the phase valve, the last piece of pipe shall be clow superlock pipe with a clow superlock plug in bell.

Gate valves shall be Mueller super seal resilient wedge valves, 250 PSI. They shall conform to AWAA C-509 specifications. Valves shall have a machined seating service to provide positive sealing with a predictable number of turns. The valve interior shall be epoxy coated on all surfaces. All valves shall open left. All valves shall be mechanical joint unless specified different.

All gate valves and valve box bases shall be blocked upright. All valve operating nuts shall not exceed 4' in depth. If operating nut is in excess of 4' in depth, it will require a valve nut extension that is approved by the service provider.

All valve boxes shall be the standard cast iron three piece type equal to the Tyler #6860 series with the proper size base. (All valves 10" and larger will require the #160 oval base.) All valve boxes will be required to be properly set to finished grade. Lids will be marked "Water".

All valve box bases will be blocked up with concrete blocks to eliminate settling on valve tops.

SECTION 5 CORPORATION STOPS AND CURB BOXES

The subdivider shall install all corporation stops and curb boxes in residential subdivisions and when the anticipated water usage and pressures are known.

Residential taps shall be 1" minimum with the following specifications:

1" services -	corporation stops -	curb stops
Mueller -	15000 or	1502-2 or
Ford -	F600	B22-444

Curb boxes shall be located one foot outside the right-of-way.

All curb boxes shall be the standard cast iron two piece type equal to the Tyler 6500 series with the proper size base. Standard box will be the 94E Box with the lid marked "Water". (All 2" services will require the enlarged bases to fit over a 2" curb stop.) All curb boxes shall be properly set to the finished grade.

All curb boxes will have curb stop rods and centering rings installed on curb stops and inside curb boxes. (Rods will be tapered, 42" long, approved by the service provider before installation.) Curb boxes are to have solid concrete block supporting its feet. Final finish curb box height is to be the responsibility of the contractor.

SECTION 6 FIRE PROTECTION

- A. Fire hydrants with two and one half (2 1/2) inch connections and one (1) large pumping connection shall be required by the sub divider in all subdivisions having adequate public water supplies.

- B. Hydrants shall be located between property lines and curbs with all outlets facing or parallel to the street.
- C. Hydrant spacing shall be approved by the Fire Department having jurisdiction. Hydrants shall be spaced so that each residence is within 600 feet of a hydrant. Hydrants shall be placed at corners of all blocks and at midblock for all blocks exceeding 800 feet in length. In addition, hydrants shall be required at the entrance and the end of all cul-de-sacs exceeding 400 feet in length.
- D. The type of hydrant and control valves shall be approved by the Fire Department and the local water provider.
- E. The minimum size of any water line shall not be less than six (6) inches in diameter and should be on circulating water lines. Size and location of waterlines shall be approved by the County Engineer and the local water provider. Minimum size of any water line shall be eight (8) inch.

SECTION 7 PRESSURE AND BACTERIA TESTING

A. Pressure Test

After the trench has been backfilled, the water main shall be subjected to water pressure of 150 PSI for 2 hours, or other requirements of water provider, measured at the point of highest elevation. Before applying test pressure, all air shall be expelled from the pipe. If hydrants or blow offs are not available at high places, the installation contractor will be responsible for making and plugging these blow offs. The County Inspector or water provider, will make the final decision on how much pipe will be pressure tested at a time. If defects are found the installation contractor shall immediately make necessary repairs at his own expense, under the direction of the County Inspector or water provider. The duration of the pressure test shall be two hours.

B. Leakage Test

A leakage test shall be conducted after the pressure test has been satisfactorily completed. Leakage is defined as the quantity of water to be supplied into the newly laid pipe to maintain the leakage test pressure of 150 PSI. The allowable leakage quantity will be determined by the County Inspector or water provider. No pipe installation will be accepted until the leakage is less than the allowable quantity. The duration of the leakage test shall be two hours.

C. Chlorination

The preferred point of application of the chlorinating agent is at the beginning of the pipeline extension or any valued section of it and through a corporated stop inserted by the installation contractor in the top of the newly laid pipe. The chlorine-bearing compounds that may be used are commercial products known as "HTH", "PERCHLORON", or "PITCHLOR". Water from the existing distribution system shall be controlled so as to flow slowly in the newly laid pipeline during the application of chlorine. Valves shall be manipulated so that the strong chlorine solution in the line being treated will not flow back into the line supplying water.

D. Bacteriological Testing

The super chlorine solution shall stay in the newly laid water main for forty-eight (48) hours from time of application. The new main will be thoroughly flushed and the first of two consecutive samples will be taken twenty-four (24) hours from the time of flushing. The second sample will be taken twenty-four (24) hours after the first sample. When taking bacteria samples, the County Inspector or water provider will control the valve at the beginning of the main extension. Bacteria samples will be collected by the installation contractor. The samples will be analyzed by an Ohio Environmental Protection Agency approved laboratory in bacterial analysis. Test result sheets will be forwarded from the lab to the Water Department. The new main extension will be turned on after the blow off corporation stops are removed and plugged with corp stop plugs.

APPENDIX B

STANDARD DRAWINGS

Effective 1-1-08

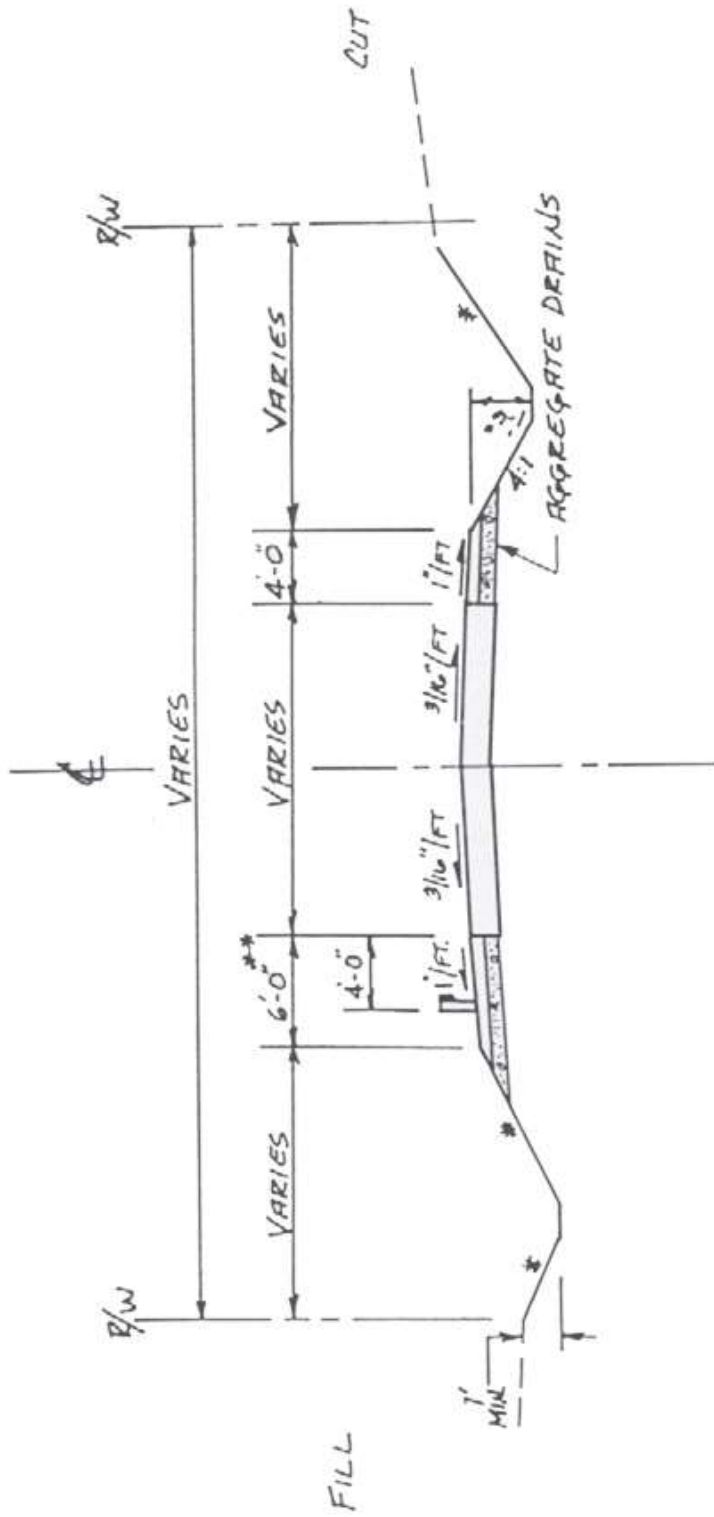

* 4:1 DESIRABLE MAXIMUM
3:1 ABSOLUTE MAXIMUM

** 4'-0" WHERE GUARD RAIL IS
NOT REQUIRED.

NOTE: 1. VERTICAL SCALE IS
EXAGGERATED

2. AGGREGATE DRAINS AT
100' INTERVALS IN
ACCORDANCE WITH
O.D.O.T. STANDARD
DRAWING DP-5

3. GUARD RAIL REQUIRED
FOR FILLS 6' OR GREATER.

STREET WITHOUT CURB AND GUTTER
DESIGN A TYPICAL SECTION

6/1/97

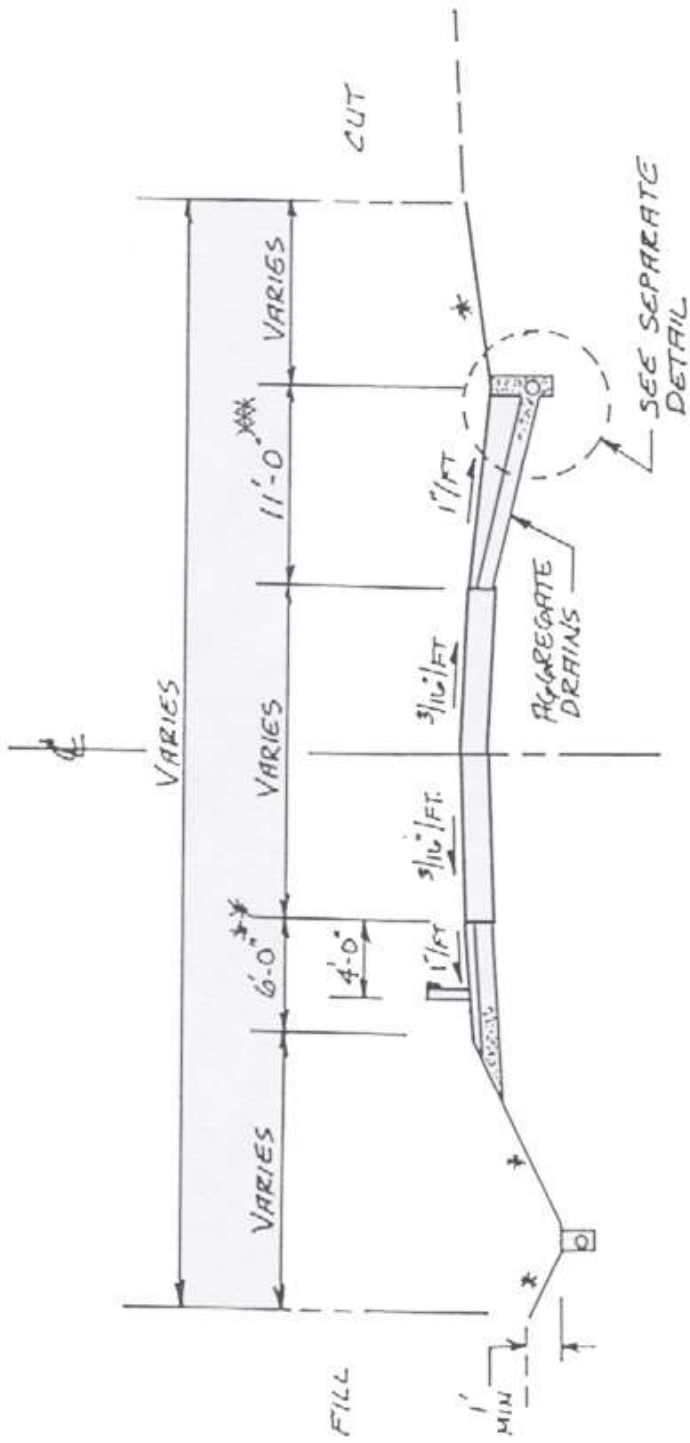

* 4:1 DESIRABLE MAXIMUM
3:1 ABSOLUTE MAXIMUM

** 4'-0" WHERE GUARD RAIL IS NOT
REQUIRED

*** 11'-0" TO DITCH BOTTOM. TILE
UNDER DRAIN TO BE LOCATED
TO OBTAIN 2' MINIMUM COVER.

NOTE: 1. VERTICAL SCALE IS EXAGGERATED
2. AGGREGATE DRAINS AT 100'
INTERVALS IN ACCORDANCE WITH
O.D.O.T. STANDARD DRAWING BPS
3. GUARD RAIL REQUIRED FOR FILLS
6' OR GREATER

STREET WITHOUT CURB AND GUTTER
DESIGN B TYPICAL SECTION

6/1/97

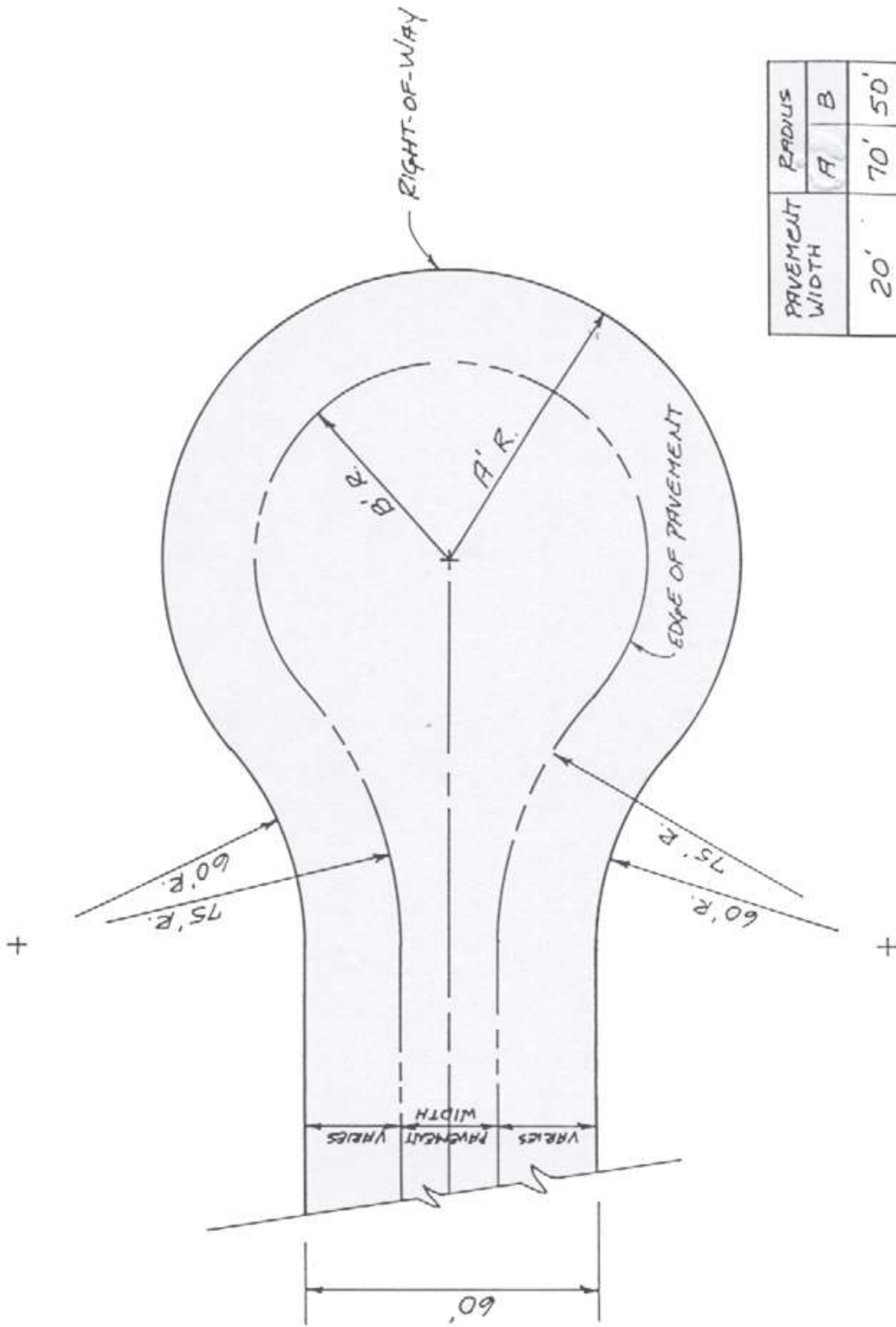

PAVEMENT WIDTH	RADIUS	
	A	B
20'	70'	50'
24'	80'	60'

NON-CURB STREET CUL-DE-SAC
(TYPICAL)

6/1/97

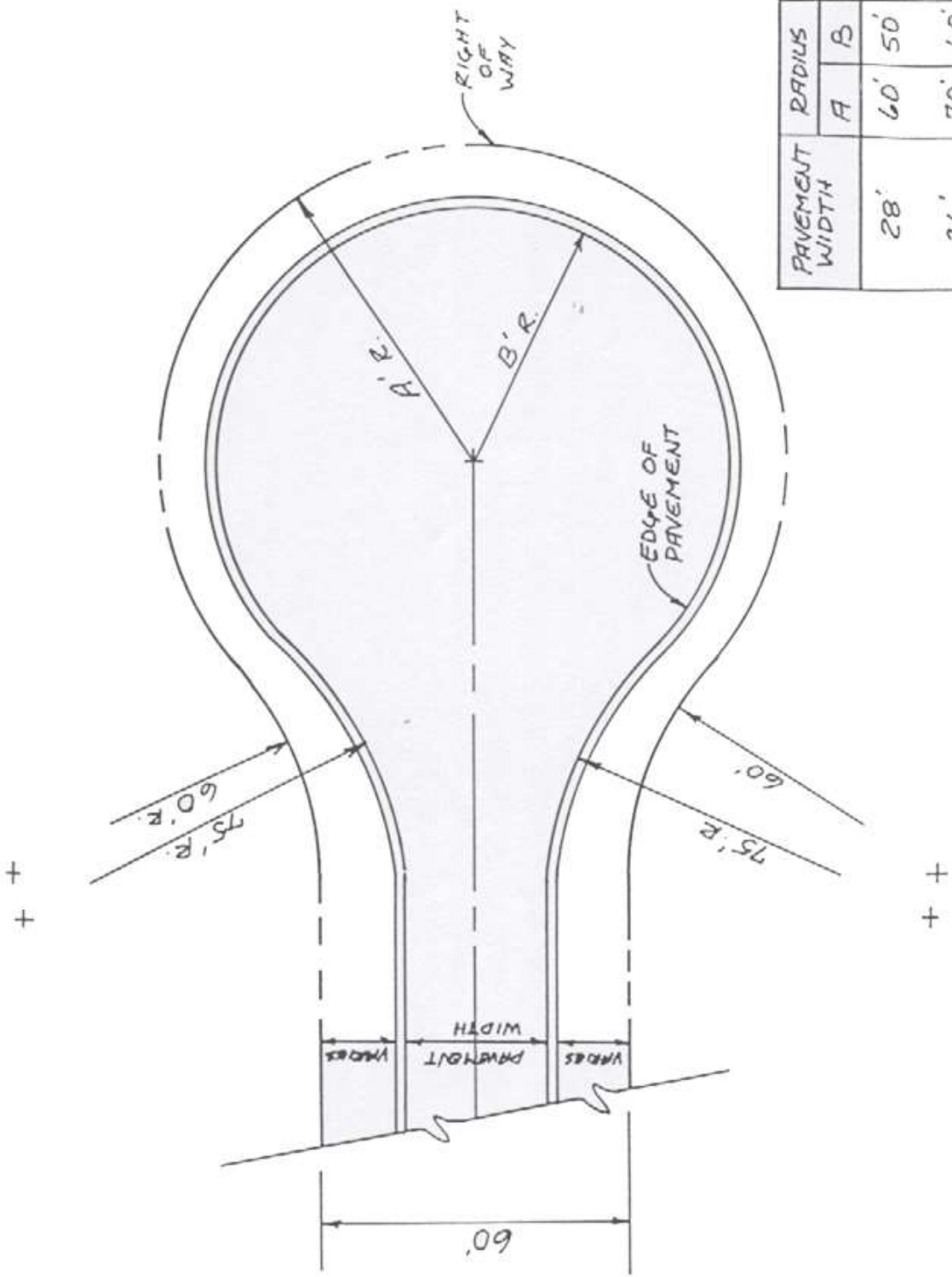

PAVEMENT WIDTH	RADIUS	
	A	B
28'	60'	50'
36'	70'	60'

CURB STREET CUL-DE-SAC
(TYPICAL)

6/1/97

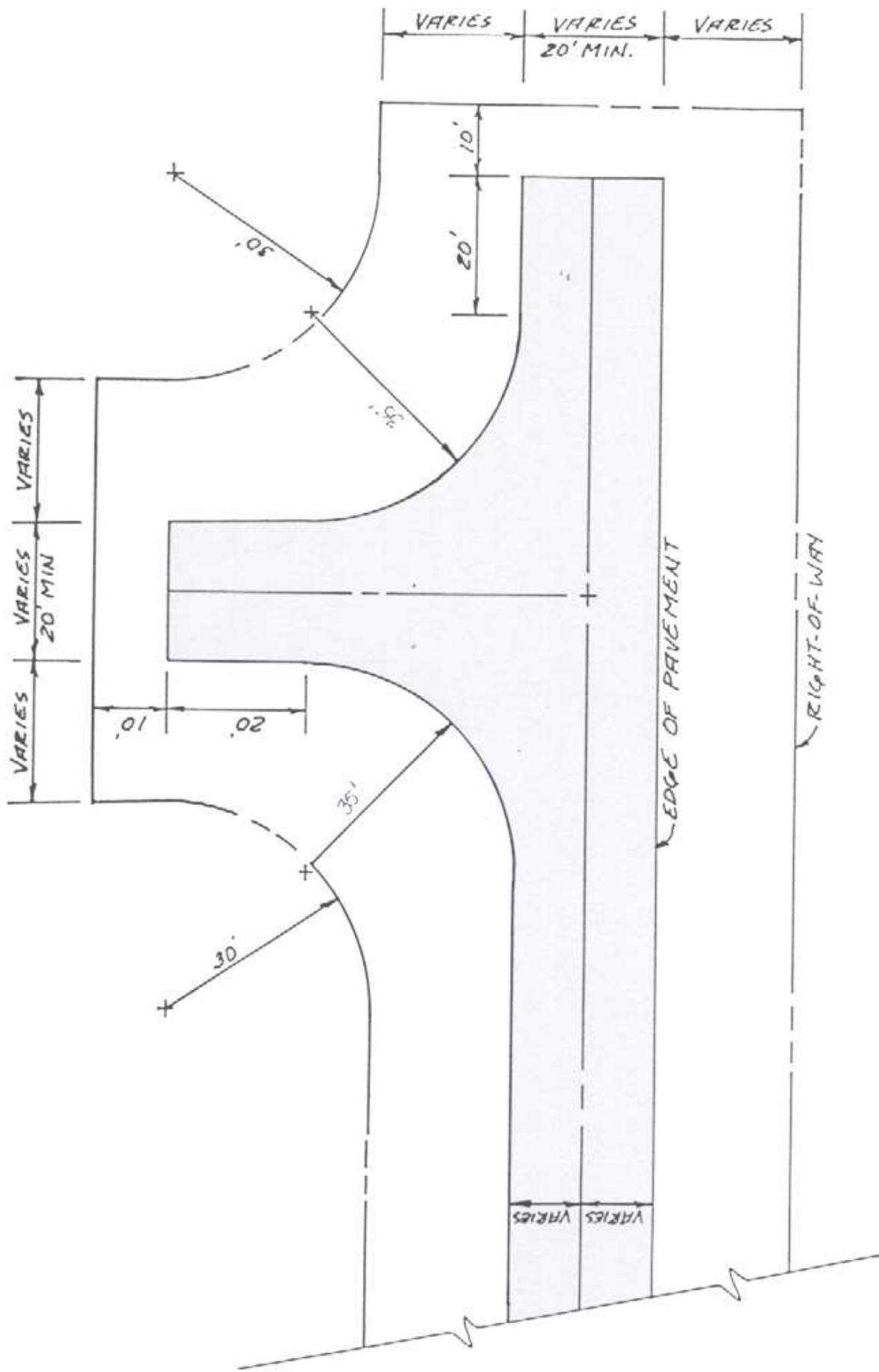

R.7

6/1/97

TEMPORARY TURN-AROUND
("T" - TYPE)

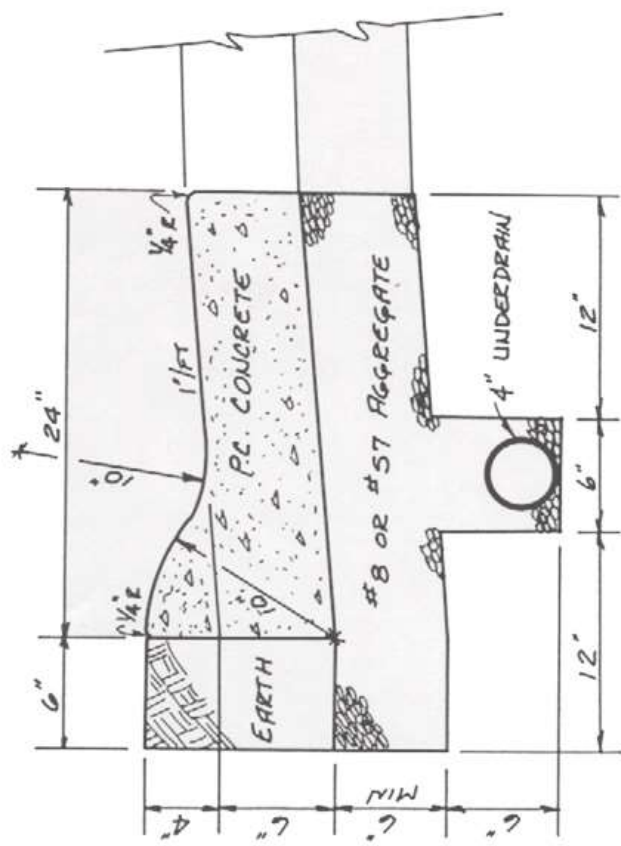

B-9

CONCRETE COMBINED CURB AND GUTTER
(LOCAL STREETS)

6/1/97

NOTE: LOCATION OF RAMP SPECIFIED BY COUNTY ENGINEER.

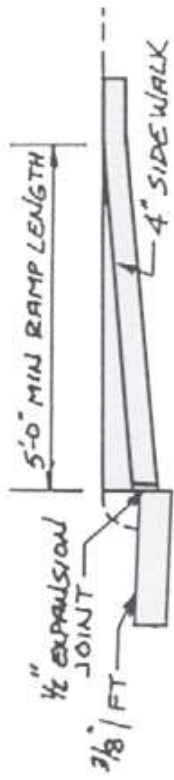

SECTION A-A

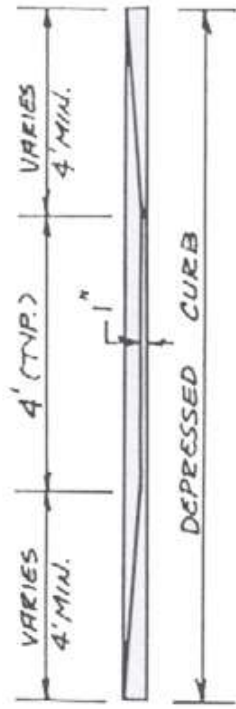

SECTION B-B

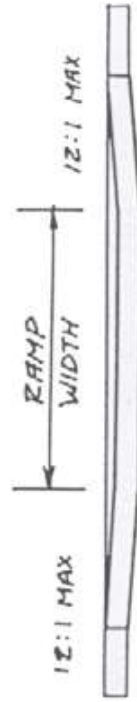

SECTION C-C

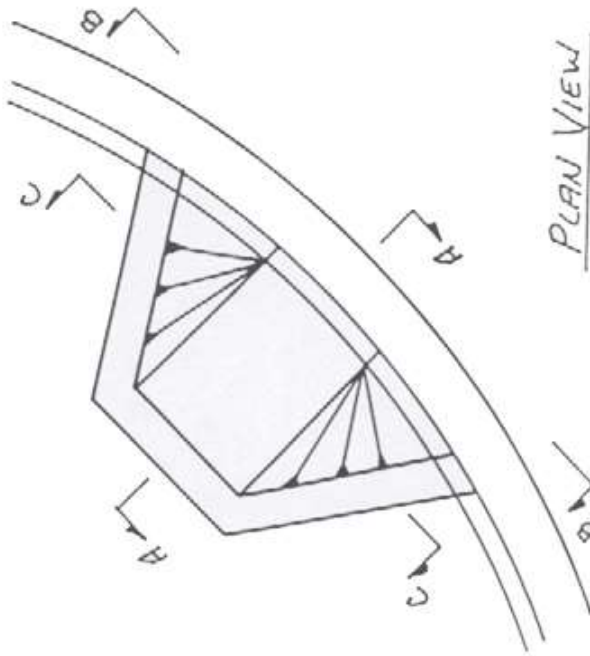

PLAN VIEW

CURB RAMP DETAIL
6/1/97

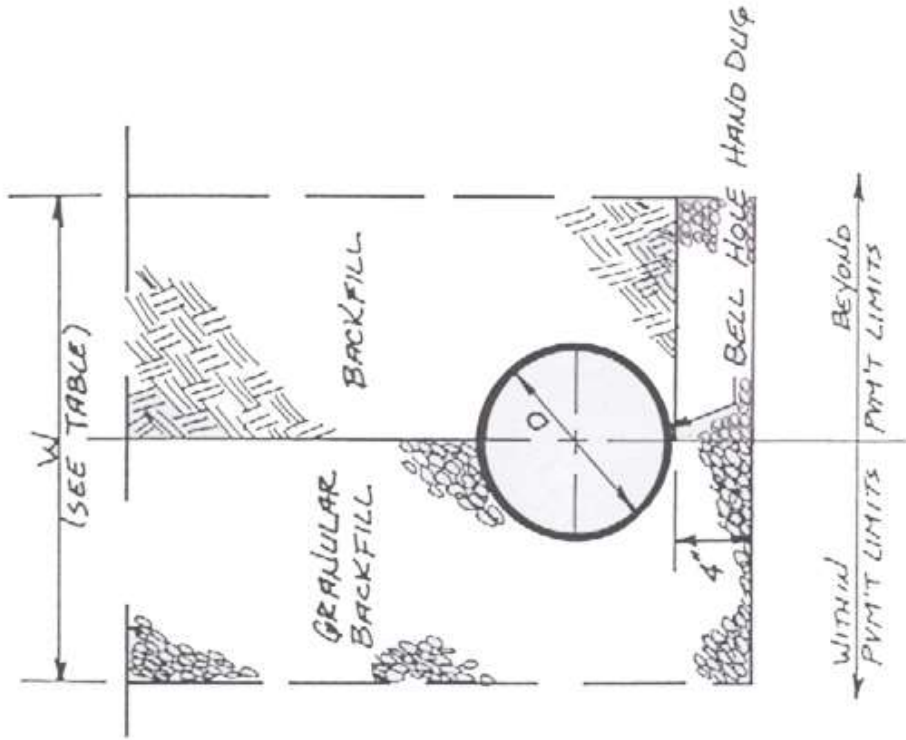

NOTE: BACKFILL: NATURAL EARTH
 FREE FROM RUBBISH
 MATERIAL, AND STONES
 LARGER THAN 6" IN
 THEIR GREATEST
 DIMENSION

BEDDING: No. 57 or. No 8
 AGGREGATE

GRANULAR
 BACKFILL: No 57 AGGREGATE

D	W (MAX)
12"	32"
15"	36"
18"	40"
21"	44"
24"	48"
27"	52"
30"	56"
36"	64"

STORM SEWER
 (TYPICAL PIPE SECTION)

6/1/97

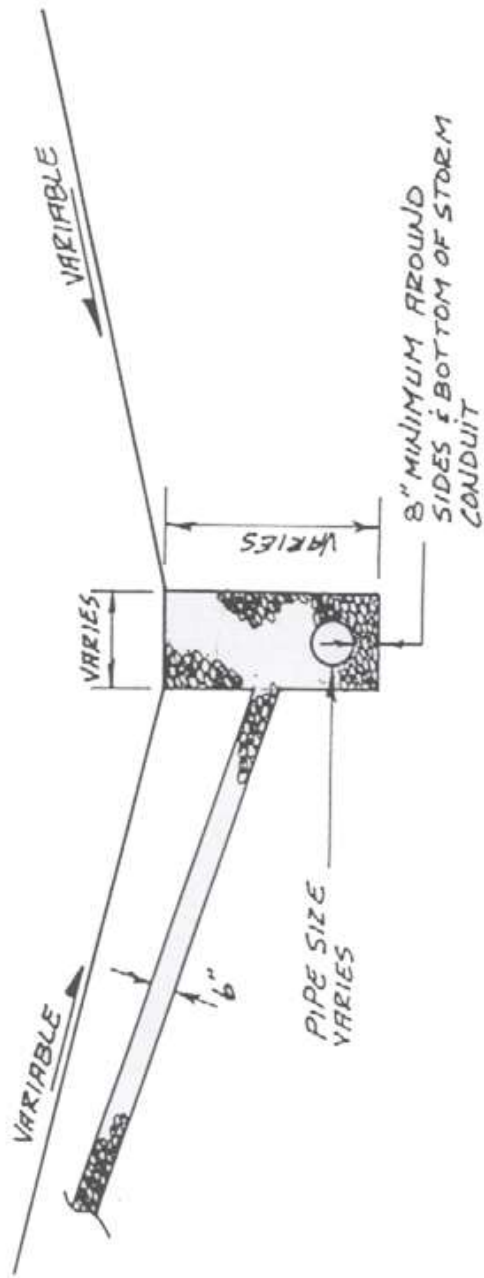

AGGREGATE DRAIN DETAIL
 (ITEM 605)

6/1/97

NOTE: ALL THE INLETS TO ROAD
DITCH STORM SEWERS SHALL
BE ON THE UPSTREAM SIDE
OF ANY DRIVEWAY.

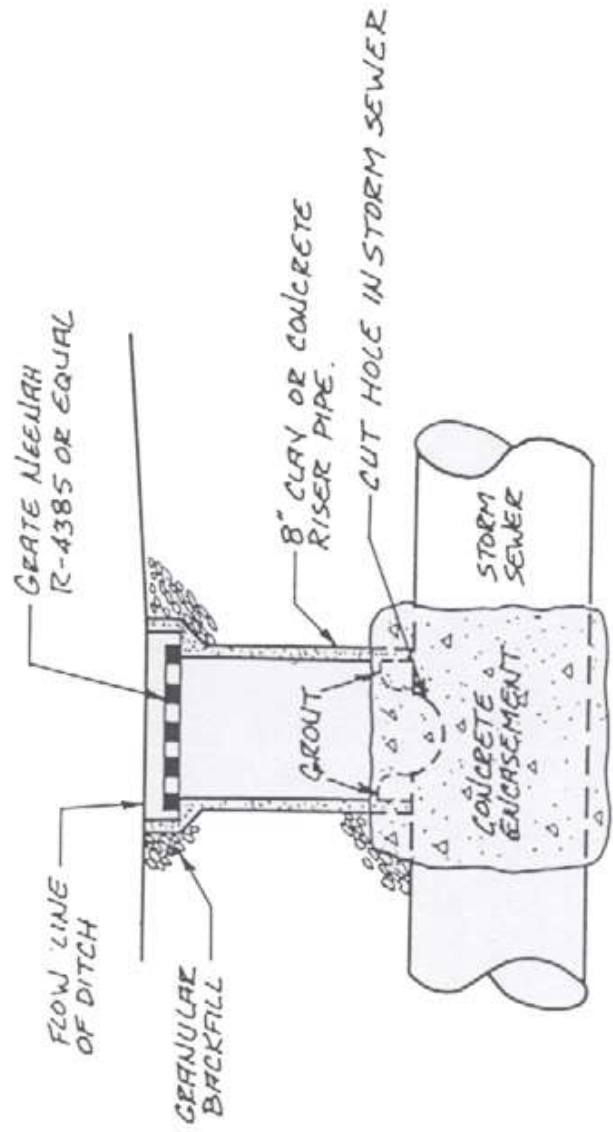

DRIVE INLET DETAIL

6/1/97

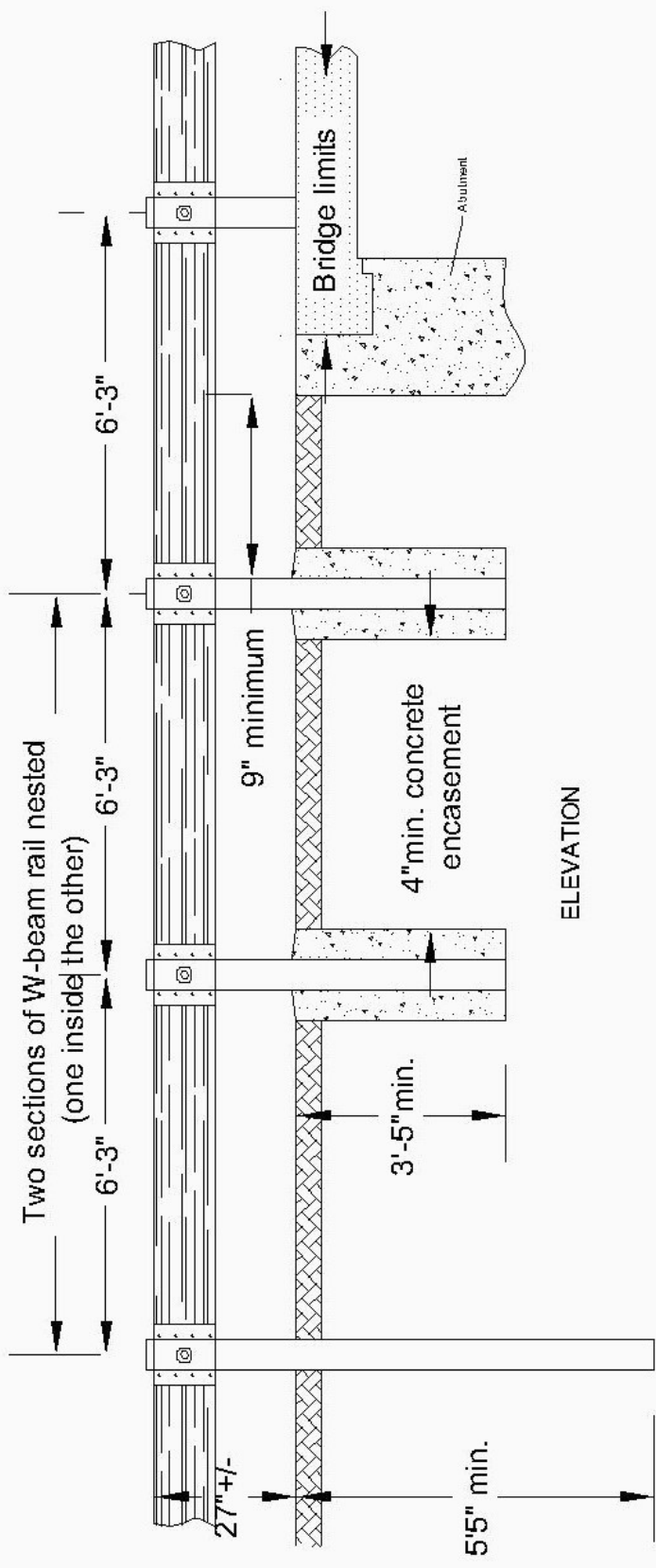
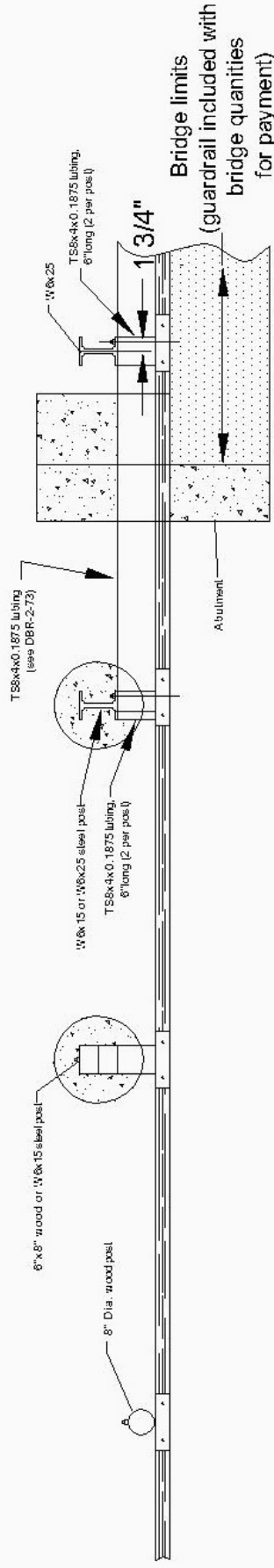

Bridge Terminal Assembly Type4UT

SCC	REV: 14 17 2015
...	Figure BDS2

Bridge Anchor Assembly Detail

Scott C. Coleman P.E., P.S.
LOGAN COUNTY ENGINEER

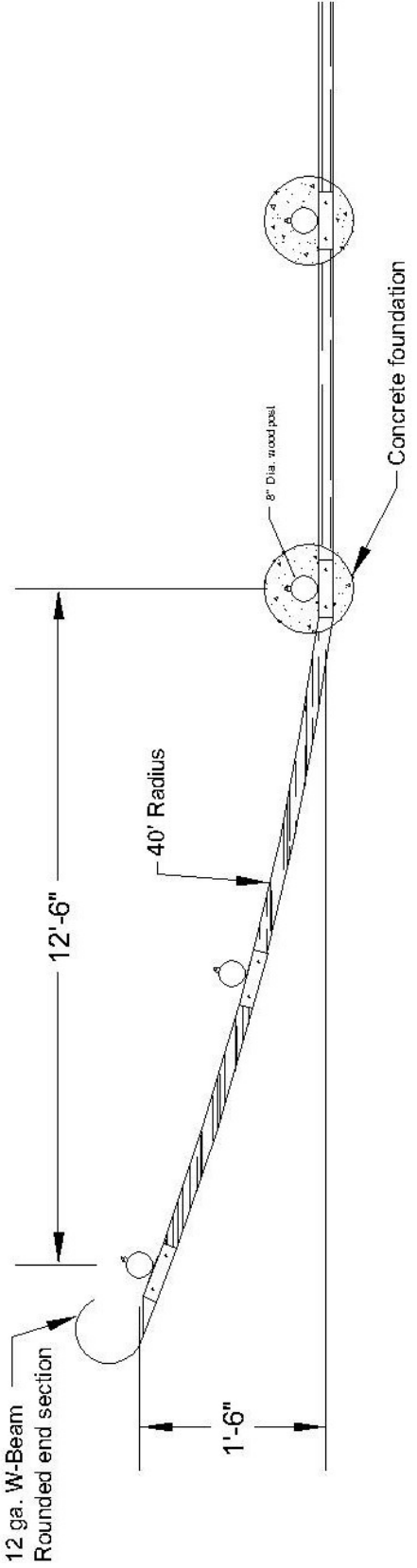

PLAN

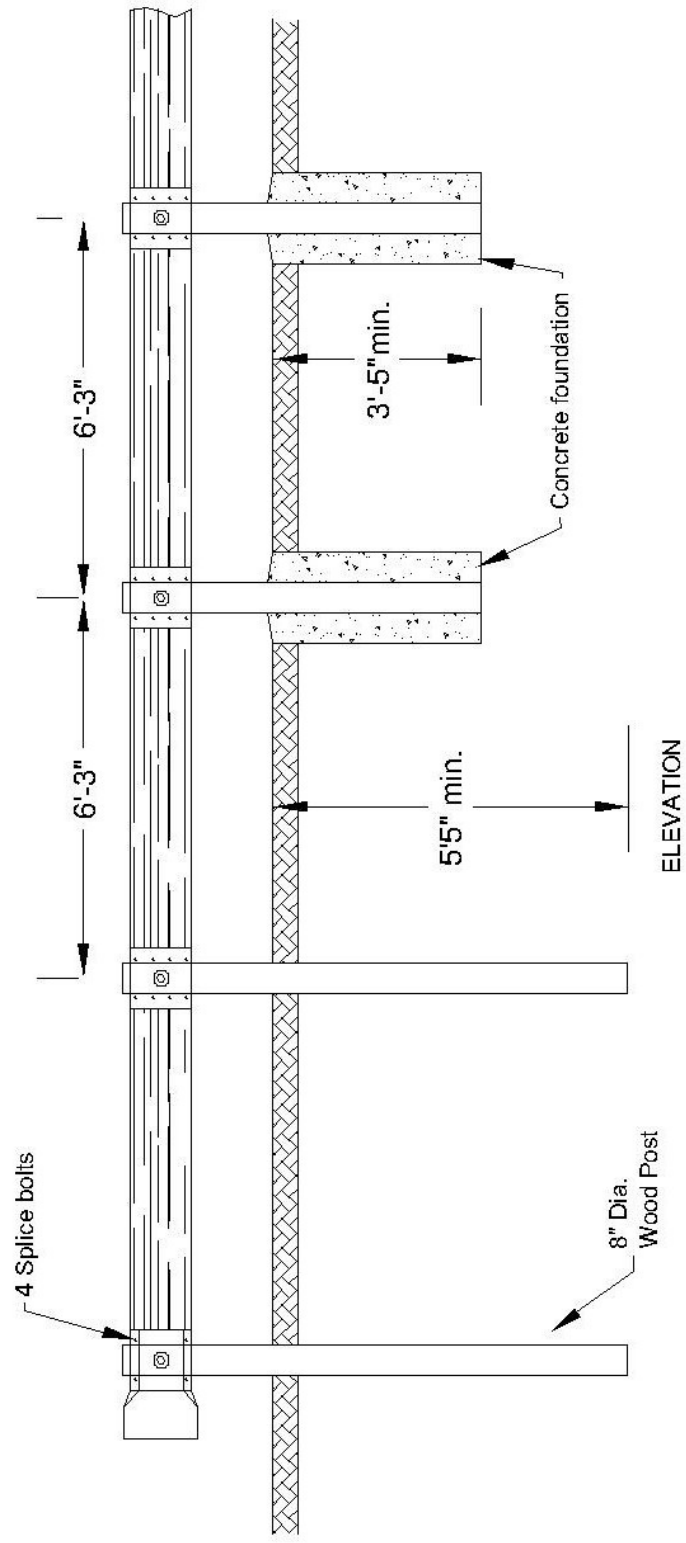

ELEVATION

Modified Type T Anchor Assembly

APPENDIX C

SCHEDULE OF FEES FOR SUBDIVISION PLATS FOR THE LOGAN-UNION-CHAMPAIGN REGIONAL PLANNING COMMISSION

Commissioners Adopted: 01/24/06

Effective:01/24/06

For the processing and filing of subdivision plats, the following fees shall be established:

FILING FEES:

1. Preliminary Plat

A charge of four hundred (\$600.00) dollars plus fifty (\$65.00) dollars per lot shall be paid at the time of filing of the preliminary plat. This fee shall cover the costs of the preliminary plat review by the LUC Regional Planning Commission.

2. Final Plat

A charge of four hundred (\$600.00) dollars plus forty (\$65.00) dollars per lot shall be paid at the time of filing of the final plat. This fee shall cover the costs of the final plat review by the LUC Regional Planning Commission.

3. Amendments

Same as filing fee.

4. Extensions

The fee for filing an extension shall be two hundred (\$300.00) dollars.

5. Tabling

The fee for tabling shall be two hundred (\$300.00) dollars.

6. Method of Payment

The filing fees shall be paid in legal tender, check or money order made payable to the Logan-Union-Champaign Regional Planning Commission. As a convenience for the developer, they may pay the required fees at one location (Logan County Engineer's Office or LUC Regional Planning Commission).

APPENDIX C

SCHEDULE OF FEES FOR SUBDIVISION PLAT REVIEW AND INSPECTION FOR THE LOGAN COUNTY ENGINEER'S OFFICE

Commissioners Adopted: 06/30/11

Effective: 07/01/11

For the processing, reviewing and inspection of subdivision plats, the following fees shall be established:

REVIEW FEES:

1. Sketch Plan Review
A charge of two hundred (\$200.00) dollars shall be paid at the time of filing of the sketch plan. This fee shall cover the costs of the sketch plan review by the Logan County Engineer.
2. Preliminary Plat
A charge of two hundred (\$200.00) dollars shall be paid at the time of filing of the preliminary plat. This fee shall cover the costs of the preliminary plat review by the Logan County Engineer.
3. Final Plat
A charge of two hundred (\$200.00) dollars shall be paid at the time of filing of the final plat. This fee shall cover the costs of the preliminary plat review by the Logan County Engineer.
4. Method of Payment
The filing fees shall be paid in legal tender, check or money order made payable to the Logan County Engineer. As a convenience for the developer, they may pay the required fees at one location (Logan County Engineer's Office or LUC Regional Planning Commission).

INSPECTION FEES:

1. Street(s)
A charge of two hundred fifty (\$250.00) dollars plus one (\$1.00) dollar per lineal foot of street or road construction shall be paid to the County Engineer at the time of approval of the preliminary plat. This fee shall cover the costs of the construction plan review and construction inspection of the subdivision.
2. Site Drainage
A charge of ten (\$10.00) dollars per acre or lot (whichever is larger) shall be paid to the County Engineer at the time of approval of the preliminary plat. This fee shall cover the costs of the storm water calculation review, sediment control plan review, and construction inspection of drainage items. Significant changes in the plans or calculations may result in additional costs being charged at the actual time and material rates as utilized.
3. Method of Payment
The inspection fees shall be paid in legal tender, check or money order made payable to the Logan County Engineer. As a convenience for the developer, they may pay the required fees at one location (Logan County Engineer's Office, LUC Regional Planning Commission, or Logan County Building Authority).

Owners or developers shall be charged for any additional labor, equipment, material or material testing costs incurred by Logan County Engineer's Office above and beyond the listed fee schedule. Additional costs shall be associated with inspection costs or significant changes to stormwater and sediment control plans.

APPENDIX C

SCHEDULE OF FEES STORMWATER AND SEDIMENT CONTROL PERMIT AND INSPECTION FOR THE LOGAN COUNTY ENGINEER'S OFFICE

Commissioners Adopted: 06/30/11

Effective: 07/01/11

For the processing, reviewing and inspection of stormwater and sediment control plans, the following fees shall be established:

PERMIT AND INSPECTION FEES:

1. Platted Subdivisions

Included in the subdivision plat inspection fees.

2. Land Development less than 1 Acre

No Charge.

3. Land Development of 1 Acre or more

A charge of fifty (\$50.00) dollars plus ten (\$10.00) dollars per lot or acre (whichever is larger) shall be paid at the time of submittal of the stormwater and sediment control plans. This fee shall cover the costs of plan review, storm water calculation review, sediment control plan review, and construction inspection. Significant changes in the plans or calculations may result in additional costs being charged at the actual time and material rates as utilized.

4. Method of Payment

The filing fees shall be paid in legal tender, check or money order made payable to the Logan County Engineer. As a convenience for the developer, they may pay the required fees at one location (Logan County Engineer's Office, LUC Regional Planning Commission, or Logan County Building Authority).

5. Owners or developers who fail to obtain a Stormwater and Sediment Control Permit from the Logan County Engineer prior to the start of construction shall be charged double fees.

6. Owners or developers shall be charged for any additional labor, equipment, material or material testing costs incurred by Logan County Engineer's Office above and beyond the listed fee schedule. Additional costs shall be associated with inspection costs or significant changes to stormwater and sediment control plans.

APPENDIX D

Effective 07-24-2017

ACCESS MANAGEMENT REGULATIONS

APPENDIX E

Effective 07-24-2017

COMMON ACCESS DRIVEWAY REGULATIONS

